



Silicone Free Particulate Filters

Models | SF0006 to SF1500

Flow Rates 6 SCFM (10 Nm³/hr) to 1500 SCFM (2550 Nm³/hr)

Our New Silicone Free Particulate Filters combine market leading Alpha filtration performance with a silicone-free manufacturing process to protect your manufacturing equipment from dust carryover and silicone contamination.

Ideally suited to applications such as paint spraying and automotive, where silicone-free air prevents costly downtime and product spoilage, our Silicone Free Filters deliver significantly reduced pressure loss and particle removal down to 0.01 micron in line with air quality standard ISO 8573-1: 2010.

Available in a range of connection sizes from 1/8" to 3" BSP Parallel, BSP Tapered and NPT threaded connections, these filters are suitable for worldwide installation.



NEW Filtration Technology

Alpha deep pleated media technology delivers a step change in performance



Silicone Free Manufacturing

Introduce filtration manufactured in a controlled environment to ensure silicone is not present or introduced during the production process



Improve Operational Efficiencies

Deliver improved production and operational efficiencies in your industrial paint plant with market leading silicone-free filtration technology

- **Market Leading Performance** Custom engineered filtration media delivers significantly reduced pressure loss and optimum performance in line with air quality standard ISO 8573-1: 2010.
- **Simplified Serviceability** Externally accessible drain, profiled bowl design and unique push fit elements ensure quick and reliable maintenance
- **Flow-Optimised Design** Advanced filter head design for optimised flow performance
- **Flexible Installation** Modular design and accessible fixings enable simple close coupling assembly
- **Corrosion Protection** Internal and external electrophoretic paint finish followed by a tough exterior polyester powder coating
- **Product Safety in Mind** Guaranteed safe housing closure with rotational safety stop

Up to 99.99% silicone-free removal of particulate contaminants when tested in accordance with ISO 12500-3





For further information please call: +44 (0) 191 417 7816

Technical Specification

Filter model	Pipe size inches	Inlet flow rate*		Dimensions mm				Weight kg	Element model
		Nm/hr	SCFM	A	B	C	D		
SF0006 (grade)	1/8	10	6	50	17	157	60	0.3	ESF0306
SF0015 (grade)	1/4	25	15	50	17	157	60	0.3	ESF0306
SF0025 (grade)	1/4	42	25	70	23	231	70	0.6	ESF0408
SF0032 (grade)	3/8	54	32	70	23	231	70	0.6	ESF0408
SF0050 (grade)	1/2	85	50	70	23	231	70	0.6	ESF0412
SF0070 (grade)	1/2	119	70	127	32	285	80	1.7	ESF0612
SF0085 (grade)	3/4	144	85	127	32	285	80	1.7	ESF0612
SF0105 (grade)	1	178	105	127	32	285	80	1.7	ESF0612
SF0125 (grade)	3/4	212	125	127	32	370	80	2.0	ESF0621
SF0175 (grade)	1	297	175	127	32	370	80	2.0	ESF0621
SF0280 (grade)	1 1/4	476	280	140	41	476	85	3.0	ESF0731
SF0320 (grade)	1 1/2	544	320	140	41	476	85	3.0	ESF0731
SF0400 (grade)	1 1/2	680	400	170	53	508	100	4.9	ESF0831
SF0450 (grade)	2	765	450	170	53	508	100	4.9	ESF0831
SF0700 (grade)	2	1189	700	170	53	708	100	5.5	ESF0850
SF0850 (grade)	2 1/2	1444	850	220	70	736	100	10.5	ESF1140
SF0900 (grade)	3	1529	900	220	70	736	100	10.5	ESF1140
SF1250 (grade)	3	2125	1250	220	70	857	100	11.5	ESF1160
SF1500 (grade)	3	2550	1500	220	70	1005	100	12.5	ESF1175

* Rated flow at 7 barg, reference conditions 1 bar (a) 20°C

Grade	RX25		RX5		RX1		RXA		RAC	
Particle removal	25 micron		5 micron		1 micron		0.01 micron		0.01 micron	
Maximum particle size class**	-		4		3		1		1	
Maximum oil carryover at 20°C (68°F)	-		-		-		-		0.003 mg/m³	
Pressure loss - clean & dry	30 mbar	0.4 psi	40 mbar	0.6 psi	75 mbar	1.1 psi	100 mbar	1.5 psi	75 mbar	1.1 psi
Pressure loss - element change	12 mths	8000 hrs	12 mths	8000 hrs	12 mths	8000 hrs	12 mths	8000 hrs	at least every 6 months	
Maximum temperature	120°C	248°F	120°C	248°F	120°C	248°F	120°C	248°F	50°C***	122°F***
Maximum working pressure	20.7 barg	300 psig	20.7 barg	300 psig	20.7 barg	300 psig	20.7 barg	300 psig	20.7 barg	300 psig
Element end cap colour	Black									

** to ISO 8573-1:2010

*** Maximum recommended operating temperature 25°C (77°F)

Pressure correction factors	For maximum flow rate, multiply model flow rate by the correction factor corresponding to the minimum operating pressure									
	4 (58)	5 (72)	6 (87)	7 (100)	8 (115)	10 (145)	12 (174)	14 (203)	16 (232)	20.7 (300)
Operating pressure barg (psig)	0.76	0.84	0.92	1	1.07	1.19	1.31	1.41	1.51	1.73
7 barg - correction factor	0.76	0.84	0.92	1	1.07	1.19	1.31	1.41	1.51	1.73

Technical Notes

- Direction of air flow is outside to in through the filter element.
- Pop Up Indicator (65DPUB3) is fitted to models SF0025 to SF0050 as standard. Differential Pressure Indicator (65DPIB) is fitted to models SF0070 to SF1500 as standard. Activated Carbon (AC) grade filters do not include DP equipment. Volt free contact options are available upon request.
- Manual Drain Valves (SFMDV25 on models SF0006 to SF0050 and SFMDVE25B on models SF0070 to SF1500), are fitted as standard.
- Activated Carbon Filters must not operate in oil saturated conditions and will not remove certain types of gases including carbon monoxide (CO) and carbon dioxide (CO₂).
- Alpha Filters are manufactured from cast aluminium alloy and are PED 2014/68/EU compliant for group 2 gases.
- Threaded connections are Rp (BSP Parallel) to ISO 7-1 or NPT to ANSI/ASME B1.20.1 if supplied within North America. Rc (BSP Taper) to ISO 7-1 also available.
- For NPT threads, add the suffix N, e.g., SF0070NRXA, and for Rc threads add the suffix C, e.g. SF0070CRXA.
- Filters are suitable for use with mineral and synthetic oils plus oil-free compressed air applications.
- Filter elements should be changed every 12 months / 8000 hours (whichever comes first). Activated Carbon Filter elements should be changed at least every 6 months.
- These filters are manufactured and tested in a controlled environment to ensure that traces of silicone or paint wetting impairment substances (PWIS) are not present on the components used, or unintentionally introduced during the production process. While the product itself does not contain significant traces of such substances, they are not designed to remove pre-existing silicone contaminants from the air stream.

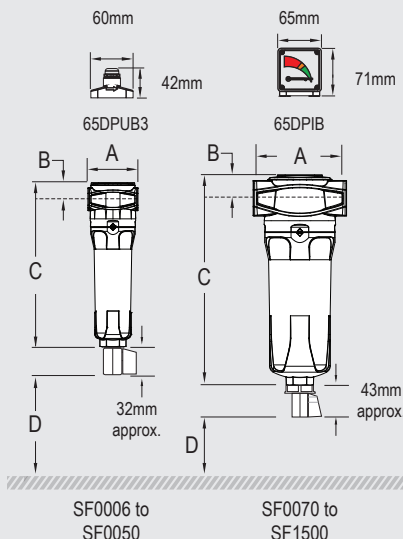

CRN



Walker Filtration Ltd Birtley Road, Washington, Tyne & Wear, NE38 9DA, United Kingdom.

tel: +44 (0) 191 417 7816 fax: +44 (0) 191 415 3748 email: sales@walkerfiltration.co.uk web: www.walkerfiltration.com