



Medical Sterile Filters

Models | A30006MS to A31500MS

Flow Rates 6 SCFM (10 Nm³/hr) to 1500 SCFM (2550 Nm³/hr)

When it comes to patient care, quality and reliability of compressed air is paramount. Walker Filtration's range of Alpha Medical Sterile Filters guarantees reliable and outstanding air purity that meets internationally certified medical performance levels.

100% integrity tested, Alpha Medical Sterile elements are guaranteed for a minimum of 100 sterilisations at 120°C (248°F), ensuring your compressed air is free from live bacteria and other submicron particles.

Designed to exceed the requirements of UK Health Technical Memorandum, HTM 02-01



Stainless Steel End Caps

Specially designed for autoclave sterilisation compatibility



100% Integrity Tested

Each element is supplied with an Air Sterilisation Certificate to guarantee the highest quality to our customers



Product Safety in Mind

Lock indication arrows assure effective sealing

- **International Validation** Designed to exceed the requirements of HTM 02-01 medical gas pipeline systems
- **Simplified Serviceability** Ribbed bowl design and unique push fit elements ensure quick and reliable maintenance
- **Product Safety in Mind** Guaranteed safe housing closure with rotational safety stop
- **Corrosion Protection** Internal and external electrophoretic paint finish followed by a tough polyester powder coating
- **Flexible Installation** Modular design and accessible fixings enable simple close coupling assembly
- **Robust and Sterilisable Materials** Manufactured from cast aluminium alloy for enhanced strength and protection





For further information please call: +44 (0) 191 417 7816

Technical Specification

Filter model	Pipe size inches	Inlet flow rate*		Dimensions mm				Weight Kg	Element model
		Nm/hr	SCFM	A	B	C	D		
A30006MS	1/8	10	6	50	17	157	60	0.3	E30306SR
A30015MS	1/4	25	15	50	17	157	60	0.3	E30306SR
A30025MS	1/4	42	25	70	23	231	70	0.6	E30408SR
A30032MS	3/8	54	32	70	23	231	70	0.6	E30408SR
A30050MS	1/2	85	50	70	23	231	70	0.6	E30412SR
A30070MS	1/2	119	70	127	32	285	80	1.7	E30612SR
A30085MS	3/4	144	85	127	32	285	80	1.7	E30612SR
A30105MS	1	178	105	127	32	370	80	2.0	E30612SR
A30125MS	3/4	212	125	127	32	370	80	2.0	E30621SR
A30175MS	1	297	175	127	32	370	80	2.0	E30621SR
A30280MS	1 1/4	476	280	140	41	476	85	3.0	E30731SR
A30320MS	1 1/2	544	320	140	41	476	85	3.0	E30731SR
A30400MS	1 1/2	680	400	170	53	508	100	4.9	E30831SR
A30450MS	2	765	450	170	53	508	100	4.9	E30831SR
A30700MS	2	1189	700	170	53	708	100	5.5	E30850SR
A30850MS	2 1/2	1444	850	220	70	736	100	10.5	E31140SR
A30900MS	3	1529	900	220	70	736	100	10.5	E31140SR
A31250MS	3	2125	1250	220	70	857	100	11.5	E31160SR
A31500MS	3	2550	1500	220	70	1005	100	12.5	E31175SR

* Rated flow at 7 barg, reference conditions 1 bar (a) 20°C

Grade	SR	
DOP efficiency**	>99.9999%	
Particle removal	0.01 micron	
Maximum operating temperature	120°C	248°F
Recommended operating temperature	50°C	122°F
Maximum autoclave temperature	134°C	273°F
Pressure Loss - clean & dry	100 mbar	1.5 psi
Maximum working pressure	20.7 barg	300 psig
Element end cap material	Stainless steel	

** As specified in HTM 02-01 medical gas pipeline systems

Pressure correction factors	For maximum flow rate, multiply model flow rate by the correction factor corresponding to the minimum operating pressure									
	4 (50)	5 (72)	6 (87)	7 (100)	8 (115)	10 (145)	12 (174)	14 (203)	16 (232)	20.7 (300)
Operating pressure barg (psig)										
7 barg – correction factor	0.76	0.84	0.92	1.00	1.07	1.19	1.31	1.41	1.51	1.73

Technical Notes

- Filter element end caps are stainless steel.
- Direction of air flow is outside to in through the filter element.
- Pop up indicators (65DPUG3) are fitted to models A30025MS to A30050MS as standard. Differential pressure indicators (65DPIG) are fitted to models A30070MS to A31500MS as standard.
- Manual drain valves (MDV25 on models A30006MS to A30050MS and MDVE25 on models A30070MS to A31500MS) are fitted as standard.
- Medical Sterile Filter elements must not operate in water or oil saturated conditions.
- Maximum steam sterilising autoclave temperature refers to the filter element ONLY. Grade SR filter elements can be steam sterilised 100 times. Each element must be autoclaved before commencement of duty.
- Pre-filtration should be used in conjunction with 0.01 micron sterile filters.
- Threaded filters are manufactured from cast aluminium alloy and are PED 2014/68/EU compliant for group 2 gases.
- Standard threaded connections are Rp (BSP Parallel) to ISO 7-1 or NPT to ANSI/ASME B1.20.1 if supplied within North America. Rc (BSP Taper) to ISO 7-1 also available - see price guide.
- For NPT threads, add the suffix N, e.g., A30070NMS, and for Rc threads add the suffix C, e.g., A30070CMS - see price guide.
- Filter elements should be changed at least every 6 months.
- Filters are suitable for use in dry air conditions only, as any liquids passing through the filter could carry bacteria and compromise sterility.

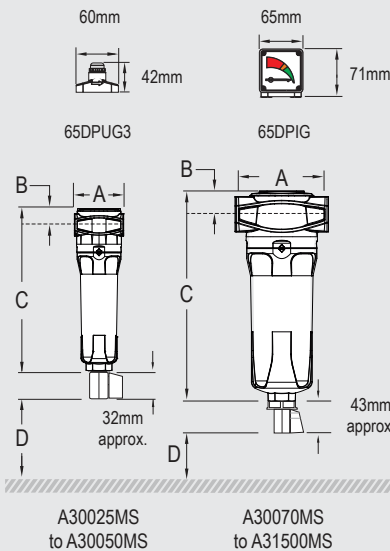

CRN



Walker Filtration Ltd Birtley Road, Washington, Tyne & Wear, NE38 9DA, United Kingdom.

tel: +44 (0) 191 417 7816 fax: +44 (0) 191 415 3748 email: sales@walkerfiltration.co.uk web: www.walkerfiltration.com