



# Water Separators

Models | A30006WS to A31500WS

Flow Rates 6 SCFM (10 Nm<sup>3</sup>/hr) to 1500 SCFM (2550 Nm<sup>3</sup>/hr)

**Integrating into Walker Filtration's compressed air filtration range, the Alpha Water Separator combines proven Alpha centrifugal technology with a new forward thinking housing design to deliver market leading water removal efficiencies – eliminating 99% bulk water with continuously low differential pressure.**

The custom engineered centrifugal module features unique vanes to eliminate points of low efficiency, and a vortex arrestor to stop re-entrainment - ensuring minimal operating pressure loss and maintaining excellent liquid removal, even at low velocities.

No replacement components are required, making Walker Filtration's Water Separators a viable and cost effective solution for removing bulk water from compressed air.

Removes up to 99% of bulk water when tested in accordance with ISO 12500-4



**Unique Centrifugal Module**

Removes 99% of bulk water even at low velocities



**Externally Accessible Drain Valve**

Eliminates the need to access inside the water separator housing when servicing the drain



**Modular Construction**

Low cost connecting kits and new filter head design enables easy close coupling assembly

- **Energy Saving** Water Separators operate with consistently low differential pressure reducing both energy consumption and operating costs
- **Flexible Installation** Modular design and accessible fixings enable simple close coupling assembly
- **Cost Effective** No replacement components required
- **Externally Accessible Drain Valve** Drain valve can be removed externally on larger models
- **Product Safety in Mind** Guaranteed safe housing closure with rotational safety stop
- **Corrosion Protection** Internal and external electrophoretic painting followed by a tough exterior polyester powder coating

For further information please visit [www.walkerfiltration.com](http://www.walkerfiltration.com)



For further information please call: **+44 (0) 191 417 7816**

# Technical Specification

Filter model	Pipe size inches	Inlet flow rate*		Dimensions mm				Weight Kg
		Nm/hr	SCFM	A	B	C	D	
A30006WS	1/8	10	6	50	17	157	60	0.3
A30015WS	1/4	25	15	50	17	157	60	0.3
A30025WS	1/4	42	25	70	23	231	70	0.6
A30032WS	3/8	54	35	70	23	231	70	0.6
A30050WS	1/2	85	50	70	23	231	70	0.6
A30070WS	1/2	119	70	127	32	285	80	1.7
A30125WS	3/4	212	125	127	32	285	80	1.7
A30175WS	1	297	175	127	32	285	80	1.7
A30280WS	1 1/4	476	280	140	41	476	85	3.0
A30320WS	1 1/2	544	320	140	41	476	85	3.0
A30400WS	1 1/2	680	400	170	53	508	100	4.9
A30700WS	2	1189	700	170	53	508	100	4.9
A30850WS	2 1/2	1444	850	220	70	420	100	8.0
A31500WS	3	2550	1500	220	70	420	100	8.0

\* Rated flow at 7 barg, reference conditions at 1 bar (a) 20°C

Grade	WS	
Minimum recommended operating temperature - automatic drain	1°C	34°F
Maximum recommended operating temperature - automatic drain	80°C	176°F
Maximum working pressure - automatic drain	16 barg	232 psig
Minimum recommended operating temperature - manual drain	1°C	34°F
Maximum recommended operating temperature - manual drain	120°C	248°F
Maximum working pressure - manual drain	20.7 barg	300 psig
Typical pressure loss at rated flow	55 mbar	0.8 psig

## Technical Notes

- Water Separators are fitted as standard with normally open float operated automatic drain valves, ADVS16 on models A30006WS to A30050WS and ADVSE16 on models A30070WS to A31500WS. Standard filters operate at 16 barg (232 psig) at 80°C (176°F). Normally closed automatic drain valves (ADVS16C) are available for low flow applications. A 20.7 barg (300 psig) range at 120°C (248°F) is available when supplied with a manual drain valve (MDV25 / MDVE25).
- Connecting kits are required to connect Water Separators to models A30006 to A31500 - see price guide.
- Wall mounting brackets are available for all models - see price guide.
- Threaded connections are Rp (BSP Parallel) to ISO 7-1 or NPT to ANSI/ASME B1.20.1 if supplied within North America. Rc (BSP Taper) to ISO 7-1 also available.
- For NPT threads, add the suffix N, e.g., A30070NWS, and for Rc threads add the suffix C, e.g. A30070CWS.

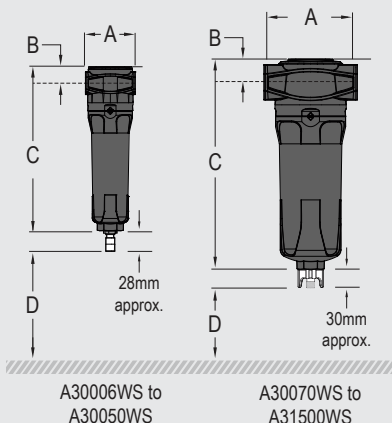

CRN



Walker Filtration Ltd Birtley Road, Washington, Tyne & Wear, NE38 9DA, United Kingdom.

tel: +44 (0) 191 417 7816 fax: +44 (0) 191 415 3748 email: sales@walkerfiltration.co.uk web: www.walkerfiltration.com