



CondensSmart Vacuum Drain

Model | CSVD1N

For System Flow Rates up to 32 SCFM (54 Nm³/hr)

Prevent contaminants from entering your vacuum system with the specialized drainage solution

The Walker Filtration CondensSmart Vacuum Drain is engineered to enhance vacuum drainage systems using a comprehensive system of electronic and pressure-based valves.

The device mimics the pressure conditions within the vacuum application, allowing condensate to drain into the receiver. The receiver senses an increase in pressure and relieves the accumulated condensate by opening the 5/2 valve.

Designed to accommodate most vacuum systems with features made to simplify service and lower power consumption, the CondensSmart Vacuum Drain is efficient in terms of maintenance and operational costs.

An innovative device designed to manage condensate in vacuum systems



Visible Performance
Easy-to-read gauges identify pressure levels within the device



User-Friendly
Control Panel with LED lights and test button indicate device status



Simple Servicing
External ball valve allows for manual condensate discharge and testing

- **UL Recognized** Meets safety standards for efficient machinery and encourages environmental sustainability
- **Service Alerts** Red LED service light on control panel will flash with alarm signals that indicate that condensate flow has been disrupted and service is needed
- **Premium Protection** IP65 protection class prevents damage from a wide range of contaminants, including dust, oil, water, and other non-corrosive material
- **Energy Efficient** Keeps energy and operational costs low with only 4W of power consumption during drainage

For further information please visit www.walkerfiltration.com



For further information please call: **+1 814 836 2900**

Technical Specification

Model	Power supply (+/- 10%)	Power Watts	Alarm contact	Working pressure range psia (bara)	Working temperature min/max °F (°C)	Maximum discharge volume at fluid oz/hr (l/hr) at 58 psig (4 barg)			Required control valve pressure psig (barg)		Inlet	Outlet (with flow limiter) O.D. Hose inches (mm)	Weight	
						Nominal	Single draining	Maximum performance	To operate the 5/2 way valve	To ensure open/close angle seat valve			lbs	kg
CSVD1N	115 VAC (50/60 Hz)	4	✓	1.45 - 26 (0.1 - 1.8)	34/140 (+1/+60)	1014 (30)	17 (0.5)	2028 (60)	58 (4)	29 (2)	NPT 1 x G 3/4" F	½ (12)	11.2	5.1

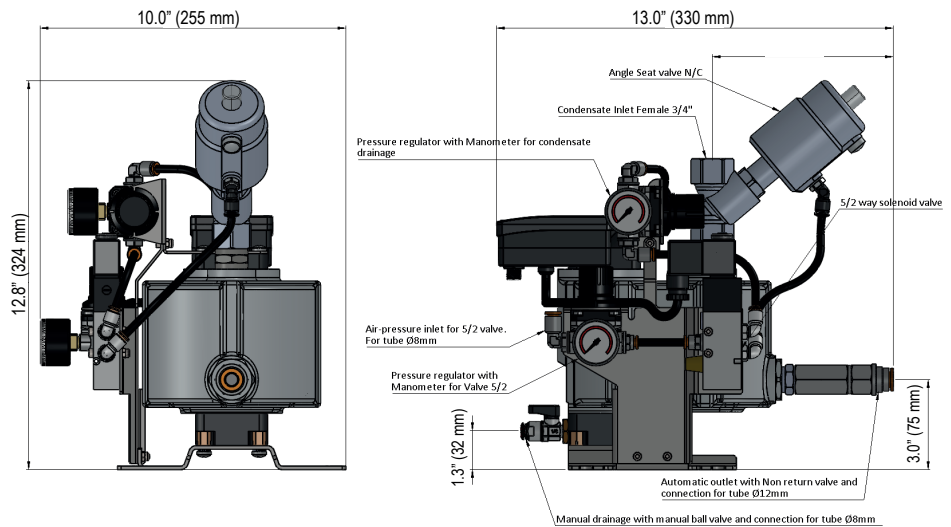

CSVD1N

Technical Notes

1. Electric connection is DIN 43650 B (EN 175301-803) for all models.
2. Protection class is NEMA 4 (IP65), with connector and correctly assembled gasket, for all models.
3. The Alarm contact is NC/NO: 240 VAC max - 1A / 30 VDC max - 1A. Alarm connection is M12 Code A 4 Poles (connector not supplied).
4. For 230 VAC and/or BSP inlet connections. Please consult your local Walker Filtration sales representative.
5. For BSP variant, order part number CSVD1.

