



CondensSmart Mechanical Float Drain

Model | CSMFD1

For System Flow Rates up to 11772 SCFM (20000 Nm³/hr)

The reliable and powerful solution to condensate management without the need for a power source.

The Walker Filtration CondensSmart Mechanical Float Drain provides an energy efficient option to eliminate compressed air loss in the condensate draining process without using an electrical outlet.

The fully automatic device uses an internal float valve that creates a low operating pressure within the collection chamber. This generates a unique, gravitational discharge system that prevents emulsions from forming before the condensate can reach the oil-water separator.

For quick installation, the CondensSmart Mechanical Float Drain does not require an electrical source, eliminating the need for external device testing and configuration.



Easy Maintenance

Externally accessible manual drain valve allows user to verify valve function



Sensory Design

The internal collection chamber maintains a small amount of condensate to prevent compressed air loss



Long-lasting Composition

Aluminum exterior and stainless steel internals prevents corrosion from condensate exposure

- **Extra Protection** Internal strainer collects large particles and contaminants found within condensate
- **Cost Effective** Powerless device connection eliminates extra money spent on electrical installation and operating energy costs
- **Safety First** Non-electronic function offers a safe alternative for systems that cannot support additional power sources



For further information please call: **+44 (0) 191 417 7816**

Technical Specification

Model	Pressure range barg (psig)		Working temperature min/max °C (°F)	Maximum capacity l/hr (gallons/hr)		Nominal volume Nm ³ /hr (SCFM)	Inlet	Orifice valve mm (inches)	Weight	
	Working pressure	Minimum recommended		at 7 barg (100 psig)	at 10 barg (145 psig)				lbs	kg
CSMFD1	0.2 to 10 (3-145)	1.5 (22)	2 - 65 (36 - 149)	44 (168)	67 (252)	20000 (11772)	G½"	2.5 (0.09)	1.3	0.6

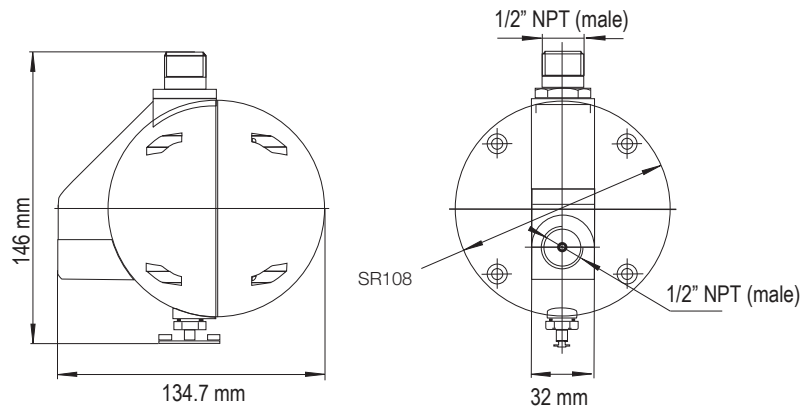

CSMFD1

Technical Notes

1. Housing material is aluminum and floating body is stainless steel.
2. The operating media is suitable for non-aggressive condensate (oil/water).
3. For NPT Variant, order part number CSMFD1N.



Walker Filtration Ltd Birtley Road, Washington, Tyne & Wear, NE38 9DA, United Kingdom.

tel: +44 (0) 191 417 7816 fax: +44 (0) 191 415 3748 email: sales@walkerfiltration.co.uk web: www.walkerfiltration.com