



OXYGEN FILTERS

Guaranteed safe and reliable filtration.



Oxygen Generation & The Need For Specialist Filtration



Oxygen is one of the basic and abundant chemical elements, making up 21% of the earth's atmosphere, and is vital for most life forms on earth. At standard pressure and temperature, oxygen is a colourless, odourless, and tasteless gas with the molecular formula O₂.

Over one hundred million tonnes of O₂ is extracted from the air every year for use in medical and industrial applications; Oxygen is an essential medicine required at all levels of the health care system for resuscitation, surgery and for various therapies. Only high quality medical grade oxygen should be given to patients, and international standards for the production of medical oxygen should be followed for patient protection.

On-site Oxygen Generation

Oxygen generators offer a cost-effective, reliable, and safe method of producing gaseous oxygen from compressed air on-site. There are several different methods used to produce oxygen on-site and, whether this is through Pressure Swing Absorption (PSA), Vacuum Swing Absorption (VSA), Cryogenic Distillation, or any other method, it is vital that purity standards are met.

The Importance of Specialist Filtration in Oxygen Generation

High quality filtration for oxygen gas generation is essential, not only to ensure the delivery of reliable compressed air and gas in line with the purity standards required for your end application, but also to protect the integrity and safety of your gas generation systems. Walker Filtration can offer the right compressed air and gas treatment solution with coalescing, particulate, and medical sterile filters, providing high quality inlet air prior to entering an oxygen generator, as well as the required filtration after the generation process.

Hazards & Risks of Concentrated Oxygen

Oxygen enrichment of the atmosphere, even by a few percent, considerably increases the risk of combustion. Because oxygen enriched air is highly reactive, it is imperative all apparatus used in the manufacture, distribution and utilisation of oxygen complies with applicable regulations, and does not contain or introduce materials that could be combustible when in contact with the gas. This includes the filtration used within an oxygen generation system. Walker Filtration's Oxygen Filters are manufactured using a state of the art environmentally clean controlled area. This ensures no contamination can be introduced into the oxygen application.

Walker Filtration provides complete peace of mind with a reliable filtration solution, cleaned in accordance with ASTM G93/ G93M.

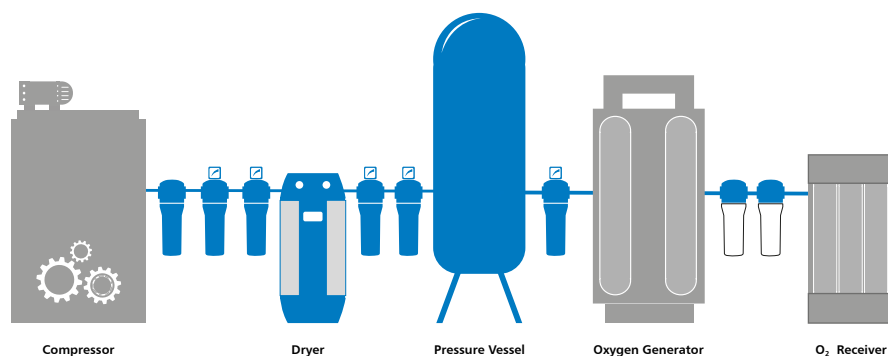

The above schematic represents a typical oxygen generation flow path including oxygen service/non-oxygen service filter installations, pre and post oxygen generator. Please contact Walker Filtration Sales Department to discuss your specific requirements and for guidance on recommended grades of filtration to achieve optimised air/gas purity.

Medical Oxygen



Medical oxygen is recognised as an essential medicine in the field of healthcare and has been used medically for over 100 years. It is crucial to treatments for critically ill patients, especially those with respiratory symptoms and low levels of oxygen in the bloodstream.

When generating medical oxygen onsite in Europe, it is necessary to comply with the specifications given in the European Pharmacopoeia monographs for "Oxygen 93 Percent". Oxygen 93 Percent is a medicinal gas produced from compressed air, containing no less than 90% percent, and no more than 96% percent of O₂.

Worldwide demand for medical oxygen has seen a significant and ongoing increase in recent years, with the prevalence of respiratory illnesses and diseases, and viruses that cause respiratory symptoms becoming more and more common. Because of this, the requirement to provide a reliable and limitless supply of oxygen on-site that can adjust according to requirements has also seen an increase in demand.

Medical Sterile Grade Filtration

It is essential that standards to produce medical oxygen are followed and quality components, including filtration, are used in the generation process.

When it comes to patient care, quality and reliability are paramount.

Walker Filtration Medical Sterile Oxygen Filters meet the required cleanliness, material and filtration standards for medical oxygen, providing safe filtration to ensure that gas purity standards are met.

Delivering clean air and oxygen where it matters most.

Our Medical Sterile Filters are designed to exceed the requirements of HTM 02-01 medical gas pipeline systems and are cleaned for oxygen service in accordance with ASTM G93/G93M.



Industrial Oxygen



Oxygen generation is essential to many industrial applications where it is necessary to have consistent, dependable, secure supplies of high-purity oxygen. In most industrial applications, the level of oxygen purity required is above 95%. Industrial applications include but are not limited to:

Metallurgy

Modern steelmaking relies heavily on the use of oxygen to enrich air and increase combustion temperatures in furnaces, as well as to replace coke with other combustible materials. Used with fuel gases in gas welding and gas cutting, oxygen must be of high quality to ensure a high cutting speed and a clean cut. Large quantities of oxygen are also used to make other metals, such as copper, lead, and zinc.

Food & Beverage

The concentration of ambient air into oxygen and ozone is key to the environmental and sustainable production in the food & beverage industry, including sanitisation of process equipment, food storage, and water bottling. Walker Filtration Alpha Series Oxygen Filters are produced from high quality, non-toxic, naturally inert raw materials and constituents, in accordance with FDA requirements for food contact as per Code of Federal Regulation (CFR), Title 21.

Aquaculture

High purity oxygen is crucial to modern day fish farming. Correctly dosed pure oxygen is essential to livestock yields, growth potential and their overall health.

Glass and Ceramics Production

Oxygen is used instead of air to optimise combustion and elevate flame temperatures in glass melting tanks. This results in better control of heating patterns, lower fuel consumption, and reduction in particulate and NOx emissions.

Semiconductors

Oxygen is used for the oxidation of silicon, one of the most critical processes in all of semiconductor manufacturing.

Pulp & Paper

In the manufacture of high-quality bleached pulp, oxygen is used in the bleaching process. New processes using oxygen, rather than chlorine, reduce water pollution and lowers costs.

Wastewater Treatment

In industrial and municipal wastewater treatment plants, oxygen is injected during the treatment process. Also known as the activated sludge process, pumping oxygen into the wastewater tank encourages the growth of bacteria and speeds up the bio-degradation process which breaks down organic matter.



The Solution

Walker Filtration's Oxygen Filters are cleaned for oxygen service in accordance with ASTM G93/G93M, delivering reliable filtration in line with the purity standards required for your end application.

Walker Filtration's Alpha Oxygen Filters are designed specifically for use in the oxygen generation process. They offer reliable and energy efficient filtration in accordance with the ASTM G93/G93M Standard Guide for Cleanliness Levels and Cleaning Methods for Materials and Equipment Used in Oxygen-Enriched Environments.

Providing high quality air pre and post oxygen generator, our oxygen filters are available in both Coalescing and Particulate (dust) filtration grades from 25 – 0.01 micron, as well as Medical Sterile.

They combine market leading Alpha filtration technology to ensure energy efficiency and superior filtration performance, with a specialised manufacturing process and strict cleaning methods to guarantee they do not contain or introduce materials that could be combustible when in contact with concentrated oxygen.

With flexible pipe sizes and flow rates to suit specific customer requirements, whatever your oxygen generator setup – we have a filtration solution for you.



Flow-Optimised Design

- Improved air flow characteristics
- Reduced energy consumption
- Reduced cost of ownership

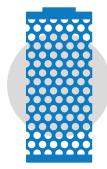

Increased Performance

- Significantly reduced differential pressure <math>< 125 \text{ mbar}</math>
- Up to 20.7 barg (300 psig) maximum working pressure
- Exceptional oil aerosol and particulate removal

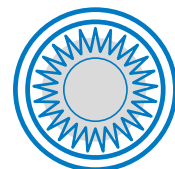

Filtration Technology

- Deep pleated media
- Housing design for flexible installation and simplified serviceability

Alpha Oxygen Range - Features & Benefits

Available in 1/8" to 3" threaded Rp (BSP Parallel), Rc (BSP Taper) or NPT port sizes, with flow rates of 6 – 1500 scfm (10 – 2550 Nm³/hr), Walker Filtration Oxygen Filters are suitable for worldwide installation. With a maximum temperature of 120°C (248°F) and a maximum operating pressure of up to 20.7 barg (300 psig).

Tested and validated in accordance with ISO 12500-1 & ISO 8573-1: 2010, Walker Filtration Oxygen filter housings and elements are manufactured using only the highest quality materials that have been specifically chosen to ensure they do not contain or introduce materials that could be combustible when in contact with oxygen gas and deliver the optimum filtration performance.



Product Safety In Mind

Single-start thread and fixed thread engagement stop guarantees safe housing closure and prevents over tightening. Lock indication arrows ensure effective sealing.

Robust Design and EP Corrosion Protection

Featuring a durable and hard wearing electrophoretic coating on both internal and external faces, followed by a tough polyester powder coating, Alpha range filters offer corrosion resistance and have been salt spray tested to ISO 9227:2012.

Simplified Serviceability

Designed with servicing and maintenance in mind, the new profiled bowl design and hexagonal spanner locator coupled with the internal unique push fit element ensures a simple, quick and reliable servicing process.





Modular Filter

Low cost connecting kits and new filter head design enables easy close coupling assembly and minimises space requirements.

Market Leading Performance

With four coalescing and particulate filtration grades available: 25 micron, 5, micron, 1 micron, and 0.01 micron, Alpha elements are energy efficient and provide class leading performance. An advanced filter design, combined with deep pleated custom engineered filtration media on general purpose and high efficiency grades, and a unique anti re-entrainment layer for exceptional oil coalescence, significantly reduces differential pressure ensuring low total cost of ownership.



Medical Sterile Grade Filtration

Designed to exceed the requirements of HTM 02-01 medical gas pipeline systems, the Walker Filtration Oxygen range also includes Medical Sterile 0.01 micron filters. Manufactured from cast aluminium alloy for enhanced strength and protection, Medical Sterile elements are guaranteed for a minimum of 100 sterilisations at 120°C (248°F) - ensuring your oxygen pipeline is free from bacteria and other sub-micron particles.



Features & Benefits

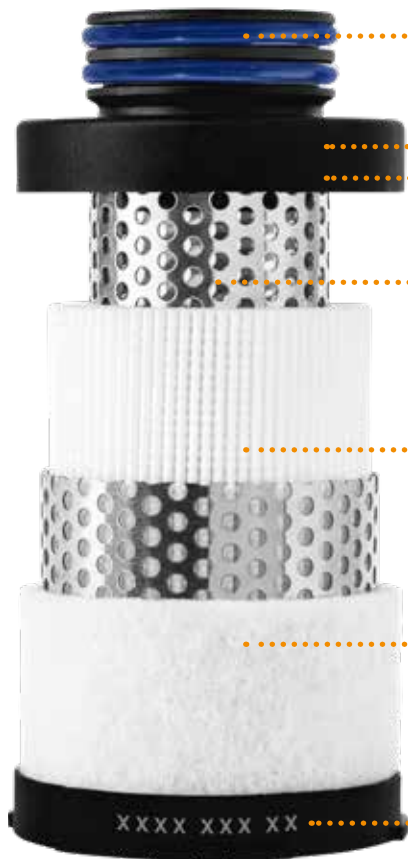

■ **Blue Viton O-rings**, for easy identification of Oxygen Filter Elements that are suitable for use in oxygen enriched air flow

■ **Push Fit** Walker Filtration Elements ensure perfect sealing within the filter housing and assist with easy removal

■ **Corrosion resistant end caps** injection moulded from glass filled nylon for added durability

■ **High quality stainless steel** cylinders provide corrosion resistance and deliver strength and stability to the element

■ **Custom engineered Hydrophobic & Oleophobic Borosilicate media** specifically developed to deliver consistently low pressure drop, Pleated element construction for high dirt holding capacity and an increased surface area is used on general purpose and high efficiency filtration grades

■ **Custom outer drainage layer** prevents oil carryover and improves coalescence performance

■ **Full traceability and easy identification** Laser etched marking enables easy grade and part number identification, branding, and batch code traceability in line with our ISO9001 manufacturing process.

Performance Assured

Walker Filtration is known for creating high quality, well-engineered, filtration solutions that offer market leading performance for an international marketplace. Alpha Series filter housings are approved to international standards and are available in a complete range of contaminant removal grades designed to meet the compressed air and gas purity requirements throughout industry.

Filter Housing Design

- ✓ 1000 hour neutral salt spray test for corrosion to ISO 9227: 2006
- ✓ Burst pressure tested in excess of 100 barg for a 5:1 safety factor
- ✓ Housings are pressure decay tested before despatch. Fine filters are 100% aerosol integrity tested

Element Technology

- ✓ **ISO 8573-1: 2010** – Compressed air purity standard
- ✓ **ISO 12500 Series** – International standard for compressed air filter testing

Independent Validation

- ✓ **Pressure Equipment Directive – 2014/68/EU**
Lloyd's Register EMEA – Notified Body No. 0038 71 Fenchurch Street, London, EC3M 4BS
- ✓ **ISO 9001 Quality Systems – LRQ0930553**
Lloyd's Register Deutschland GmbH, Überseeallee 10, 20457 Hamburg, Germany - Notified Body No 0525.
- ✓ **CRN Approved – CRN0E22360** – For use within Canada

Make It Yours: Custom Branded Products to Fit Your Portfolio

For over 35 years the Walker Filtration team has specialised in OEM solutions.

We understand the importance of reinforcing and enhancing a customer's brand, and ensuring that aftermarket sales are effectively captured.



Branding Solutions

We can customise filters so they seamlessly integrate into your gas generation systems, ensuring brand consistency and helping to capture aftermarket sales.

Every OEM solution developed by our team is unique. We take care of brand management, bespoke packaging, language support, unique part numbers, logistical details, and are dedicated to reducing the amount of time it takes to get your product to market.

Expert Technical And Transitional Support

Our fully trained sales and technical teams have extensive knowledge and experience in helping our customers launch new products and transition product vendors. They will work with you to create unique part numbers, provide technical and sales training, marketing support, and so much more.

We also offer an extensive aftermarket element portfolio to ensure you can still service any current filtration products you have in the field.

Walker Filtration Product Ranges

Walker Filtration offer a comprehensive range of compressed air filtration and drying products:



Water Separators



Dryers



Medical Vacuum



Duplex Filters



Flanged Filters



Alternative Elements



Medical Sterile

For our full product range and further information please visit: www.walkerfiltration.com or contact your nearest Walker Filtration sales department.

Coalescing and Particulate Filters

Technical Specification

Coalescing and Particulate Filter Model	Pipe size inches	Inlet flow rate*		Dimensions mm				Weight Kg	Element model
		Nm ³ /hr	SCFM	A	B	C	D		
O20006 (grade)	1/8	9.5	5.7	50	17	157	60	0.3	EO20306 (grade)
O20015 (grade)	1/4	23.8	14.3	50	17	157	60	0.3	EO20306 (grade)
O20025 (grade)	1/4	39.9	23.8	70	23	231	70	0.6	EO20408 (grade)
O20032 (grade)	3/8	51.3	30.4	70	23	231	70	0.6	EO20408 (grade)
O20050 (grade)	1/2	80.8	47.5	70	23	231	70	0.6	EO20412 (grade)
O20070 (grade)	1/2	113.1	66.5	127	32	285	80	1.7	EO20612 (grade)
O20085 (grade)	3/4	136.8	80.8	127	32	285	80	1.7	EO20612 (grade)
O20105 (grade)	1	169.1	99.8	127	32	285	80	1.7	EO20612 (grade)
O20125 (grade)	3/4	201.4	118.8	127	32	370	80	2.0	EO20621 (grade)
O20175 (grade)	1	282.2	166.3	127	32	370	80	2.0	EO20621 (grade)
O20280 (grade)	1 1/4	452.2	266.0	140	41	476	85	3.0	EO20731 (grade)
O20320 (grade)	1 1/2	516.8	304.0	140	41	476	85	3.0	EO20731 (grade)
O20400 (grade)	1 1/2	646.0	380.0	170	53	508	100	4.9	EO20831 (grade)
O20450 (grade)	2	726.8	427.5	170	53	508	100	4.9	EO20831 (grade)
O20700 (grade)	2	1129.6	665.0	170	53	708	100	5.5	EO20850 (grade)
O20850 (grade)	2 1/2	1371.8	807.5	220	70	736	100	10.5	EO21140 (grade)
O20900 (grade)	3	1452.6	855.0	220	70	736	100	10.5	EO21140 (grade)
O21250 (grade)	3	2018.8	1187.5	220	70	857	100	11.5	EO21160 (grade)
O21500 (grade)	3	2422.5	1425.0	220	70	1005	100	12.5	EO21175 (grade)

* Rated flow at 7 barg, reference conditions 1 bar (a) 20°C, calculated using 0.95 Gas Density Factor based on 93% oxygen saturation

Grade	X25 / RX25		X5 / RX5		X1 / RX1		XA / RXA	
Particle removal	25 micron		5 micron		1 micron		0.01 micron	
Max particle size class**	-		4		3		1	
Max oil content**	-		4		3		1	
Max oil carryover at 20°C (68°F)	10 mg/m ³		5 mg/m ³		0.3 mg/m ³		0.01 mg/m ³	
Pressure loss - clean & dry	30 mbar	0.4 psi	40 mbar	0.6 psi	55 mbar	0.8 psi	85 mbar	1.2 psi
Pressure loss - saturated	50 mbar	0.7 psi	75 mbar	1.1 psi	125 mbar	1.8 psi	125 mbar	1.8 psi
Pressure loss - element change	12 mths	8000 hrs	12 mths	8000 hrs	12 mths	8000 hrs	12 mths	8000 hrs
Max temperature	120°C	248°F	120°C	248°F	120°C	248°F	120°C	248°F
Max working pressure	20.7 barg	300 psig	20.7 barg	300 psig	20.7 barg	300 psig	20.7 barg	300 psig
Max autoclave temperature	N/A	N/A	N/A	N/A	N/A	N/A	N/A	N/A
Element end cap colour	Black							

** to ISO 8573-1: 2010

Pressure correction factors	for maximum flow rate, multiply model flow rate by the correction factor corresponding to the minimum operating pressure									
Operating pressure barg (psig)	4 (58)	5 (72)	6 (87)	7 (100)	8 (115)	10 (145)	12 (174)	14 (203)	16 (232)	20.7 (300)
7 barg - correction factor	0.76	0.84	0.92	1.00	1.07	1.19	1.31	1.41	1.51	1.73

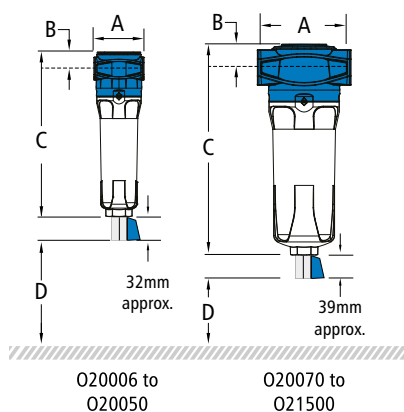

Technical Notes

- Direction of flow is inside to out through the filter element for coalescing grades (X25, X5, X1 and XA), and outside to in for particulate grades (RX25, RX5, RX1 and RXA)
- All Oxygen Filters are fitted as standard with Manual Drain Valves, VMDV25 on models O20006 to O20050, VMDVE25B on models O20070 to O20700, and VMDVE25M on models O20850 to O21500. Standard filters can operate at 20.7 barg (300 psig) range at 120°C (248°F).
- Alpha Oxygen Filters are manufactured from cast aluminium alloy and are PED 2014/68/EU compliant for group 1 and group 2 gases.
- Threaded connections are Rp (BSP Parallel) to ISO 7-1 or NPT to ANSI/ASME B1.20.1 if supplied within North America. Rc (BSP Taper) to ISO 7-1 also available.
- Filters are suitable for use with mineral and synthetic oils plus oil-free compressed air applications.
- Filter elements should be changed every 12 months / 8000 hours (whichever comes first).
- Walker Filtration genuine spare and aftermarket parts must be used, failure to do so will void product warranty. Walker Filtration shall not be held liable for damages suffered by the customer if Walker Filtration genuine oxygen rated spare and aftermarket parts are not used.
- All Walker Filtration Alpha Oxygen Filters are produced from high quality, non-toxic, naturally inert raw materials and constituents, in accordance with FDA requirements for food contact as per Code of Federal Regulation (CFR), Title 21.
- Other filtration grades are available. Please contact sales for specific requests.

Medical Sterile Filters

Technical Specification

Filter Model	Pipe size inches	Inlet flow rate*		Dimensions mm				Weight Kg	Element model
		Nm ³ /hr	SCFM	A	B	C	D		
O20006MS	1/8	9.5	5.7	50	17	157	60	0.3	EO20306SR
O20015MS	1/4	23.8	14.3	50	17	157	60	0.3	EO20306SR
O20025MS	1/4	39.9	23.8	70	23	231	70	0.6	EO20408SR
O20032MS	3/8	51.3	30.4	70	23	231	70	0.6	EO20408SR
O20050MS	1/2	80.8	47.5	70	23	231	70	0.6	EO20412SR
O20070MS	1/2	113.1	66.5	127	32	285	80	1.7	EO20612SR
O20085MS	3/4	136.8	80.8	127	32	285	80	1.7	EO20612SR
O20105MS	1	169.1	99.8	127	32	285	80	1.7	EO20612SR
O20125MS	3/4	201.4	118.8	127	32	370	80	2.0	EO20621SR
O20175MS	1	282.2	166.3	127	32	370	80	2.0	EO20621SR
O20280MS	1 1/4	452.2	266.0	140	41	476	85	3.0	EO20731SR
O20320MS	1 1/2	516.8	304.0	140	41	476	85	3.0	EO20731SR
O20400MS	1 1/2	646.0	380.0	170	53	508	100	4.9	EO20831SR
O20450MS	2	726.8	427.5	170	53	508	100	4.9	EO20831SR
O20700MS	2	1129.6	665.0	170	53	708	100	5.5	EO20850SR
O20850MS	2 1/2	1371.8	807.5	220	70	736	100	10.5	EO21140SR
O20900MS	3	1452.6	855.0	220	70	736	100	10.5	EO21140SR
O21250MS	3	2018.8	1187.5	220	70	857	100	11.5	EO21160SR
O21500MS	3	2422.5	1425.0	220	70	1005	100	12.5	EO21175SR

* Rated flow at 7 barg, reference conditions 1 bar (a) 20°C, calculated using 0.95 Gas Density Factor based on 93% oxygen saturation

Grade	SR	
DOP efficiency**	>99.9999%	
Particle removal	0.01 micron	
Maximum operating temperature	120°C	248°F
Recommended operating temperature	50°C	122°F
Maximum autoclave temperature	134°C	273°F
Pressure Loss - clean & dry	100 mbar	1.5 psi
Maximum working pressure	20.7 barg	300 psig
Element end cap material	Stainless steel	

** As specified in HTM 02-01 medical gas pipeline systems

Pressure correction factors	for maximum flow rate, multiply model flow rate by the correction factor corresponding to the minimum operating pressure									
Operating pressure barg (psig)	4 (58)	5 (72)	6 (87)	7 (100)	8 (115)	10 (145)	12 (174)	14 (203)	16 (232)	20.7 (300)
7 barg - correction factor	0.76	0.84	0.92	1.00	1.07	1.19	1.31	1.41	1.51	1.73

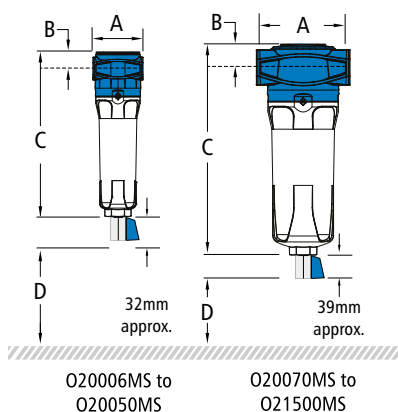

Technical Notes

- Direction of air flow is inside to out through the filter element. Filter element end caps are stainless steel.
- All Oxygen Filters are fitted as standard with Manual Drain Valves, VMDV25 on models O20006 to O20050, VMDVE25B on models O20070 to O20700, and VMDVE25M on models O20850 to O21500. Standard filters can operate at 20.7 barg (300 psig) range at 120°C (248°F).
- Alpha Oxygen Filters are manufactured from cast aluminium alloy and are PED 2014/68/EU compliant for group 1 and group 2 gases.
- Threaded connections are Rp (BSP Parallel) to ISO 7-1 or NPT to ANSI/ASME B1.20.1 if supplied within North America. Rc (BSP Taper) to ISO 7-1 also available.
- Pre-filtration should be used in conjunction with 0.01 micron sterile filters.
- Medical Sterile Filter elements must not operate in water or oil saturated conditions and should be changed at least every 6 months.
- Maximum steam sterilising autoclave temperature refers to the filter element ONLY. Oxygen grade SR filter elements can be steam sterilised 100 times. Each element must be autoclaved before commencement of duty.
- Each element is supplied with an Air Sterilisation Certificate to guarantee the highest quality to our customers.
- Oxygen SR grade filters are suitable for use in dry air conditions only, as any liquids passing through the filter could carry bacteria and compromise sterility.
- Walker Filtration genuine spare and aftermarket parts must be used, failure to do so will void product warranty. Walker Filtration genuine oxygen rated spare and aftermarket parts are not used.
- All Walker Filtration Alpha Oxygen Filters are produced from high quality, non-toxic, naturally inert raw materials and constituents, in accordance with FDA requirements for food contact as per Code of Federal Regulation (CFR), Title 21.



W WALKER FILTRATION

The ultimate filtration & drying technology

Walker Filtration Ltd

Birtley Road, Washington,
Tyne & Wear, NE38 9DA, UK
tel +44 (0) 191 417 7816
fax +44 (0) 191 415 3748
email sales@walkerfiltration.co.uk
web www.walkerfiltration.com



THE QUEEN'S AWARDS
FOR ENTERPRISE:
INNOVATION
2016



Walker Filtration Inc.

4748 Pacific Avenue
Erie, PA 16506, USA
tel +1 814 836 2900
fax +1 814 836 7921
email usa@walkerfiltration.com
web www.walkerfiltration.com/en-us

Walker Filtration Pty Ltd

16-18 Lindon Court,
Tullamarine VIC 3043, Australia
tel +61 (0)3 9330 4144
fax +61 (0)3 9330 4177
email sales@walkerfiltration.com.au
web www.walkerfiltration.com/en-au

Walker Filtration Ltd Japan

Amikura Bldg., 2nd Floor
3-8-12 Haramachida, Machida-city
Tokyo 194-003, Japan
tel +81 (0) 42 850 8836
fax +81 (0)3 6685 2974
email japan@walkerfiltration.com
web www.walkerfiltration.com/ja