



Medical Vacuum

Models | A30025MV to A31500MV

Designed for use in critical medical applications to remove solid, liquid and bacterial contamination in vacuum systems, Walker Filtration's Medical Vacuum Filters guarantee a safe and reliable product that is trusted by hospitals worldwide.

Situated on the suction side of a vacuum pump, Alpha Series Medical Vacuum Filters are essential to avoiding damage to vacuum pumps and preventing potentially hazardous biological contagions from being exhausted into the surrounding environment.

Third party tested and validated in accordance with HTM 02-01, NFPA 99, ISO 7396-1 and AS 2896



NEW Filtration Technology

Filtration efficiency in excess of 99.9999% (HTM 02-01 specifies >99.995%)



Product Safety in Mind

Easily removable sterilisable drain flask and Differential Pressure monitor supplied as standard



Push Fit Element Design

Quick and easy maintenance with unique push fit element design



- **High Efficiency Medical Grade Filter Element** Custom engineered filter media and deep pleat element technology provides minimal pressure loss and filtration efficiencies in excess of international medical gas standards
- **International Medical Gas Standards** Fully compliant with global medical gas pipeline systems standards ISO 7396-1, HTM 02-01, NFPA 99 and AS 2896
- **Quick and Easy Maintenance** Unique push fit element design allows for easy maintenance, significantly reducing service time and contact time for service engineers with contaminated filter elements
- **Advanced Filtration Technology** Low pressure loss borosilicate glass microfiber-media and open cell reticulated foam pre-filtration layer captures particulates, bacteria and liquid aerosols reducing energy consumption and overall system costs for low total cost of ownership
- **Corrosion Protection** Internal and external electrophoretic painting followed by a tough exterior polyester powder coating
- **Product Safety in Mind** Quality design and build. Guaranteed safe housing closure with rotational safety stop





Technical Specification

Filter model	Pipe size inches	Maximum Rated Flow at Atmospheric pressure		Maximum Rated Flow at an Operating Vacuum (Suction) Pressure of 475 mmHg (63 kPa) [383.25 mbar(a)]				Dimensions mm				Weight Kg	Element model
		Free Air Aspirated (FAA)		Free Air Aspirated (FAA)		Rarified Air Flow		A	B	C	D		
		NI/min	SCFM	NI/min	SCFM	L/min	CFM						
A30025MV	1/4	48	1.7	25	0.9	66	2.3	70	23	231	70	0.6	E30408MV
A30032MV	3/8	82	2.9	45	1.6	119	4.2	70	23	231	70	0.6	E30408MV
A30050MV	1/2	187	6.6	105	3.7	278	9.8	70	23	231	70	0.6	E30412MV
A30070MV	1/2	340	12.0	190	6.7	502	17.7	127	32	285	80	1.7	E30612MV
A30085MV	3/4	420	14.8	235	8.3	621	21.9	127	32	285	80	1.7	E30612MV
A30105MV	1	495	17.5	275	9.7	727	25.7	127	32	285	80	1.7	E30612MV
A30175MV	1	870	30.7	485	17.1	1282	45.3	127	32	370	80	2.0	E30621MV
A30280MV	1 1/4	1285	45.4	720	25.4	1904	67.2	140	41	476	85	3.0	E30731MV
A30320MV	1 1/2	1340	47.3	720	26.5	1983	70.0	140	41	476	85	3.0	E30731MV
A30400MV	1 1/2	1875	66.2	1050	37.1	2776	98.0	170	53	508	100	4.9	E30831MV
A30450MV	2	1965	69.4	1100	38.8	2908	102.7	170	53	508	100	4.9	E30831MV
A30700MV	2	2770	97.8	1550	54.7	4098	144.7	170	53	708	100	5.5	E30850MV
A30850MV	2 1/2	4700	166.0	2630	92.9	6953	245.6	220	70	736	100	10.5	E31140MV
A30900MV	3	5360	189.3	3000	105.9	7932	280.1	220	70	736	100	10.5	E31140MV
A31250MV	3	5985	211.4	3350	118.3	8857	312.8	220	70	857	100	11.5	E31160MV
A31500MV	3	6340	223.9	3550	125.4	9386	331.4	220	70	1005	100	12.5	E31175MV

NOTE: Rated flows are stated at HTM 02-01 conditions. For flows at other operating vacuum pressures, please consult Walker Filtration Ltd. Operating vacuum (suction) pressure is stated at the filter outlet (i.e. vacuum pump or suction side) Standard (reference) atmosphere: 101.325 kPa (1013.25 mbar(a)), 20°C

Grade	MV
Element end cap colour	Black
Particle removal efficiency	> 99.9999% (HTM 02-01 specifies >99.995%)*
Maximum temperature	60°C (140°F)
Pressure loss - clean & dry	≤ 3 kPa (30 mbar / 0.44 psig)
Maximum working pressure	0.5 barg (7 psig)
Maximum working vacuum	Full Vacuum

*In accordance with BS 3928:1969. Fully validated to ISO 7396-1, AS 2896 and NFPA 99. Certificates available on request

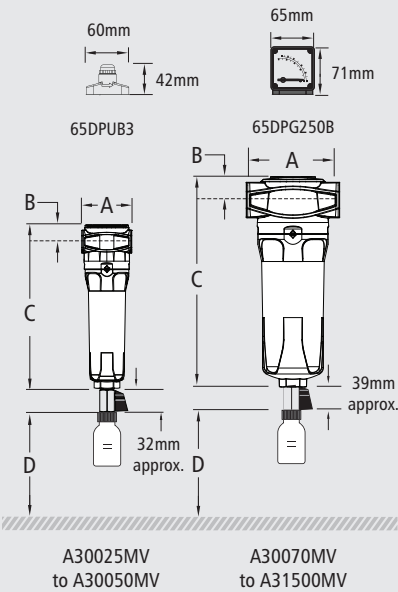

Atmospheric Pressure
760 mmHg (101 kPa)

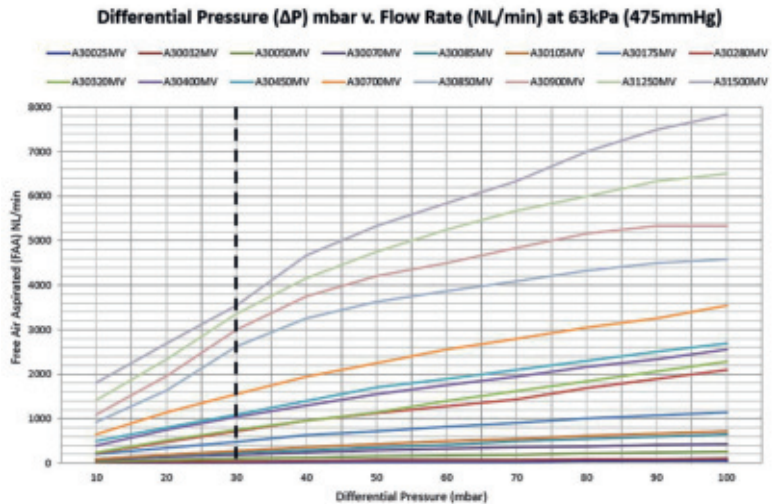
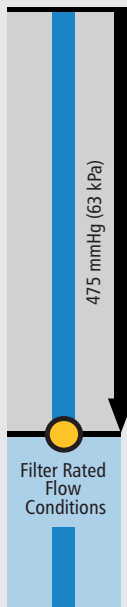

Technical Notes

- Direction of flow is outside to inside through the element.
- Filter elements should be replaced at least every 6 months.
- Pop Up Indicator (65DPUB3) is fitted to models A30025 to A30050 as standard. Differential pressure gauges (65DPG250B) are fitted to models A30070 to A31500 as standard. Volt free contact options are available - see price guide.
- Manual drain valves (MDVE25B) are fitted to all models. Sterilisable glass drain flasks are supplied as standard, 100ml for models A30025MV to A30105MV and 250ml for models A30175MV to A31500MV.
- Threaded connections are Rp (BSPP parallel) to ISO 7-1 or NPT to ANSI/ASME B1.20.1 if supplied within North America. Rc (BSP Taper) to ISO 7-1 also available.
- For NPT connections, add the suffix 'N' e.g. A30070NMV. For Rc threads add the suffix 'C' e.g. A30070CMV - see price guide.

