

Compressed Air Dust Filters

Models | A3011 to A3303

Flow Rates 6 SCFM (10 Nm³/hr) to 1500 SCFM (2550 Nm³/hr)

Advancements in new technology, improved low differential pressure and a step change in performance ensures the New Alpha Dust Filters are the ideal solution for installation downstream of regenerative compressed air and gas dryers.

With exceptional results in particle retention of up to 99.999%, and significantly reduced pressure loss, the New Alpha Dust Filter ensures total protection of manufacturing equipment from dust carryover.

Available in a range of connection sizes from 1/8" to 3", the New Alpha Dust Filters have a maximum temperature of 120°C (248°F) and increased operating pressure of 20.7 barg (300 psig).



**Up to 99.999%
particle retention
when tested in
accordance with
ISO 12500-3**



NEW Modular Filter

Low cost connecting kits and new filter head design enables easy close coupling assembly



NEW Filtration Technology

New Alpha deep pleated media technology delivers a step change in performance



Product Safety in Mind

Lock indication arrows ensure effective sealing

- **Flow-Optimised Design** Advanced filter head design for optimised flow performance
- **Flexible Installation** Modular design and accessible fixings enable simple close coupling assembly
- **Market Leading Performance** Custom engineered filtration media delivers optimum performance in line with air quality standard ISO 8573-1: 2010
- **Simplified Serviceability** New profiled bowl design and push fit elements ensure quick and reliable maintenance
- **Corrosion Protection** Internal and external electrophoretic paint finish followed by a tough exterior polyester powder coating
- **Colour Coded Element End Caps** Easy and accurate grade identification

For further information please email sales@walkerfiltration.com.au



Technical Specification

Filter model	Pipe size inches	Inlet flow rate*		Dimensions mm				Weight Kg	Element model
		Nm ³ /hr	SCFM	A	B	C	D		
A3011 (grade)	1/8	10	6	50	17	157	60	0.25	E30306 (grade)
A3021 (grade)	1/4	25	15	50	17	157	60	0.25	E30306 (grade)
A3022 (grade)	1/4	42	25	70	24	231	70	0.6	E30408 (grade)
A3031 (grade)	3/8	54	32	70	24	231	70	0.6	E30408 (grade)
A3051 (grade)	1/2	85	50	70	24	231	70	0.6	E30412 (grade)
A3052 (grade)	1/2	119	70	127	32	285	80	1.7	E30612 (grade)
A3071 (grade)	3/4	144	85	127	32	285	80	1.7	E30612 (grade)
A3101 (grade)	1	178	105	127	32	285	80	1.7	E30612 (grade)
A3072 (grade)	3/4	212	125	127	32	371	80	2	E30621 (grade)
A3102 (grade)	1	297	175	127	32	371	80	2	E30621 (grade)
A3122 (grade)	1 1/4	476	280	170	53	508	100	4.9	E30831 (grade)
A3151 (grade)	1 1/2	680	400	170	53	508	100	4.9	E30831 (grade)
A3201 (grade)	2	765	450	170	53	508	100	4.9	E30831 (grade)
A3202 (grade)	2	1189	700	170	53	708	100	5.5	E30850 (grade)
A3251 (grade)	2 1/2	1444	850	220	70	736	100	10.5	E31140 (grade)
A3301 (grade)	3	1529	900	220	70	736	100	10.5	E31140 (grade)
A3302 (grade)	3	2125	1250	220	70	857	100	11.5	E31160 (grade)
A3303 (grade)	3	2550	1500	220	70	1005	100	12.5	E31175 (grade)

* Rated flow at 7 barg, reference conditions at 1 bar (a) 20°C

Grade	RX25		RX5		RX1		RXA		RAC	
Particle removal	25 micron		5 micron		1 micron		0.01 micron		0.01 micron	
Maximum particle size class**	-		4		3		1		1	
Maximum oil carryover at 20°C (68°F)	-		-		-		-		0.003 mg/m ³	
Pressure loss - clean & dry	30 mbar	0.4 psi	40 mbar	0.6 psi	75 mbar	1.1 psi	100 mbar	1.5 psi	75 mbar	1.1 psi
Pressure loss - element change	12 mths	8000 hrs	12 mths	8000 hrs	12 mths	8000 hrs	12 mths	8000 hrs	at least every 6 mths	
Maximum temperature	120°C	248°F	120°C	248°F	120°C	248°F	120°C	248°F	50°C***	122°F***
Maximum working pressure	20.7 barg	300 psig	20.7 barg	300 psig	20.7 barg	300 psig	20.7 barg	300 psig	20.7 barg	300 psig
Element end cap colour	Black		Green		Red		Blue		Black	

** to ISO 8573-1: 2010 *** Maximum recommended operating temperature 25°C (77°F)

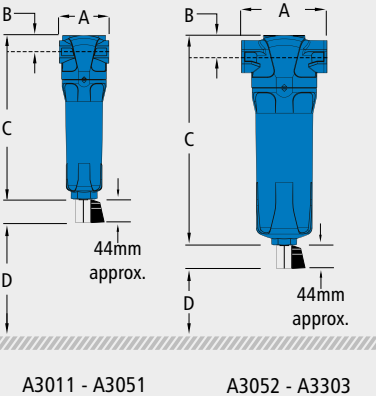
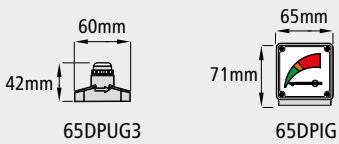

Pressure correction factors	For maximum flow rate, multiply model flow rate by the correction factor corresponding to the minimum operating pressure									
	Operating pressure barg (psig)	4 (58)	5 (72)	6 (87)	7 (100)	8 (115)	10 (145)	12 (174)	14 (203)	16 (232)
7 barg - correction factor	0.76	0.84	0.92	1	1.07	1.19	1.31	1.41	1.51	1.6

Technical notes

- Direction of air flow is outside to in through the filter element.
- Pop up indicators (65DPUG3) are fitted to models A3022 to A3051 as standard. Differential pressure indicators (65DPIG) are fitted to models A3052 to A3303 as standard. Activated Carbon (AC) grade filters do not include DP equipment. Volt free contact options are available upon request - see price guide.
- Manual drain valves (MDV25 on models A3011 to A3051 and MDVE25 on models A3052 to A3303), are fitted as standard.
- Activated Carbon Filters must not operate in oil saturated conditions and will not remove certain types of gases including carbon monoxide (CO) and carbon dioxide (CO₂).
- New Alpha Filters are manufactured from cast aluminium alloy and are PED 2014/68/EU compliant for group 2 gases.
- Threaded connections are Rp (BSP Parallel) to ISO 7-1 or NPT to ANSI/ASME B1.20.1 if supplied within North America. Rc (BSP Taper) to ISO 7-1 also available.
- For NPT threads, add the suffix N, e.g., A3052NRXA, and for Rc threads add the suffix C, e.g. A3052CRXA.
- Filters are suitable for use with mineral and synthetic oils plus oil-free compressed air applications.
- Filter elements should be changed every 12 months / 8000 hours (whichever comes first). Activated carbon filter elements should be changed every 6 months.

