



Medical Vacuum

Models | A3052MV to A3303MV

Designed for use in critical medical applications to remove solid, liquid and bacterial contamination in vacuum systems, Walker Filtration's Medical Vacuum Filters guarantee a safe and reliable product that is trusted by hospitals worldwide.

Situated on the suction side of a vacuum pump, the New Alpha Series of Medical Vacuum Filters are essential to avoiding damage to vacuum pumps and preventing potentially hazardous biological contagions from being exhausted into the surrounding environment.

Third party tested and validated in accordance with HTM 02-01, NFPA 99, ISO 7396-1 and AS 2896



NEW Filtration Technology

Filtration efficiency in excess of 99.9999% (HTM 02-01 specifies >99.995%)



Product Safety in Mind

Easily removable sterilisable drain flask and Differential Pressure monitor supplied as standard



Push Fit Element Design

Quick and easy maintenance with unique push fit element design



- High Efficiency Medical Grade Filter Element** Custom engineered filter media and deep pleat element technology provides minimal pressure loss and filtration efficiencies in excess of international medical gas standards
- International Medical Gas Standards** Fully compliant with global medical gas pipeline systems standards ISO 7396-1, HTM 02-01, NFPA 99 and AS 2896
- Quick and Easy Maintenance** Unique push fit element design allows for easy maintenance, significantly reducing service time and contact time for service engineers with contaminated filter elements
- Advanced Filtration Technology** Low pressure loss borosilicate glass microfiber-media and open cell reticulated foam pre-filtration layer captures particulates, bacteria and liquid aerosols reducing energy consumption and overall system costs for low total cost of ownership
- Corrosion Protection** Internal and external electrophoretic painting followed by a tough exterior polyester powder coating
- Product Safety in Mind** Quality design and build. Guaranteed safe housing closure with rotational safety stop

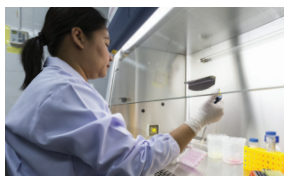



Technical Specification

Filter model	Pipe size inches	Maximum Rated Flow at an Operating Vacuum (Suction) Pressure of 475 mmHg (63 kPa) [383.25 mbar(a)]						Dimensions mm				Weight Kg	Element model
		Free Air Aspirated (FAA)			Rarified Air Flow			A	B	C	D		
		Nl/min	Nm ³ /hr	SCFM	L/min	m ³ /hr	CFM						
A3052MV	1/2	190	11.4	6.7	502	30.1	17.7	127	32	285	80	1.7	E30612MV
A3071MV	3/4	235	14.1	8.3	621	37.3	21.9	127	32	285	80	1.7	E30612MV
A3101MV	1	275	16.5	9.7	727	43.6	25.7	127	32	285	80	1.7	E30612MV
A3102MV	1	485	29.1	17.1	1282	76.9	45.3	127	32	371	80	2.0	E30621MV
A3122MV	1 1/4	950	57.0	33.5	2512	150.7	88.7	170	53	508	100	4.9	E30831MV
A3151MV	1 1/2	1050	63.0	37.1	2776	166.6	98.0	170	53	508	100	4.9	E30831MV
A3201MV	2	1100	66.0	38.8	2908	174.5	102.7	170	53	508	100	4.9	E30831MV
A3202MV	2	1550	93.0	54.7	4098	245.9	144.7	170	53	708	100	5.5	E30850MV
A3251MV	2 1/2	2630	157.8	92.9	6953	417.2	245.6	220	70	736	100	10.5	E31140MV
A3301MV	3	3000	180.0	105.9	7932	475.9	280.1	220	70	736	100	10.5	E31140MV
A3302MV	3	3350	201.0	118.3	8857	531.4	312.8	220	70	857	100	11.5	E31160MV
A3303MV	3	3550	213.0	125.4	9386	563.1	331.4	220	70	1005	100	12.5	E31175MV

NOTE: Rated flows are stated at HTM 02-01 conditions. For flows at other operating vacuum pressures, please consult Walker Filtration Ltd. Operating vacuum (suction) pressure is stated at the filter outlet (i.e. vacuum pump or suction side) Standard (reference) atmosphere: 101.325 kPa (1013.25 mbar(a)), 20°C

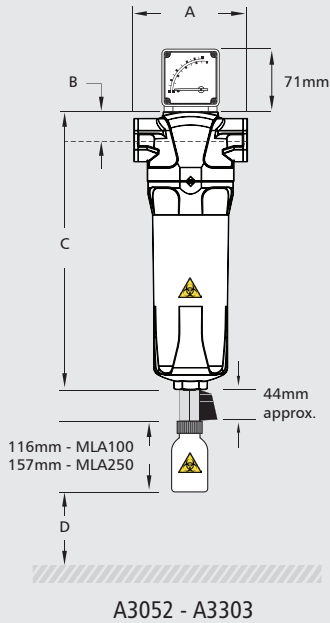

Grade	MV
Element end cap colour	Black
Particle removal efficiency	> 99.9999% (HTM 02-01 specifies >99.995%)*
Maximum temperature	60°C (140°F)
Pressure loss - clean & dry	≤ 3 kPa (30 mbar / 0.44 psi)
Maximum working pressure	0.5 barg (7 psig)
Maximum working vacuum	Full Vacuum

*In accordance with BS 3928:1969. Fully validated to ISO 7396-1, AS 2896 and NFPA 99. Certificates available on request

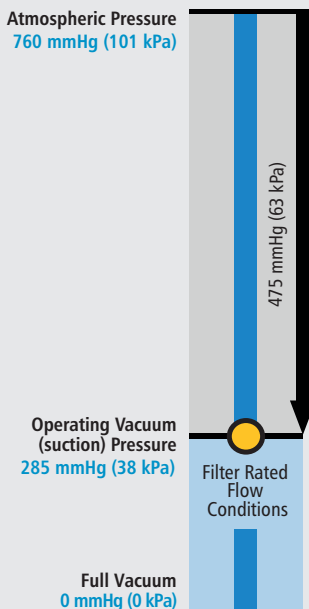
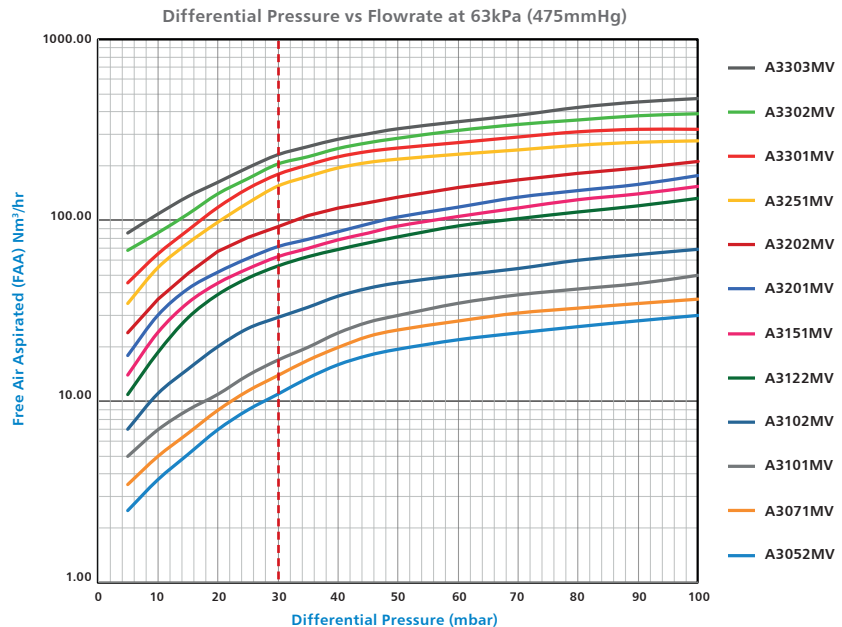

Technical notes

- Direction of flow is outside to inside through the element.
- Filter elements should be replaced at least every 6 months.
- Differential pressure gauges (65DPG250B) are fitted to all models as standard. Volt free contact options are available - see price guide.
- Manual drain valves (MDVE25) are fitted to all models. Sterilisable glass drain flasks are supplied as standard, 100ml for models A3052MV to A3101MV and 250ml for models A3102MV to A3303MV.
- Threaded connections are Rp (BSP parallel) to ISO 7-1 or NPT to ANSI/ASME B1.20.1 if supplied within North America. Rc (BSP Taper) to ISO 7-1 also available.
- For NPT connections, add the suffix 'N' e.g. A3052NMV. For Rc threads add the suffix 'C' e.g. A3052CMV.

